



## INDIAN INSTITUTE OF MANAGEMENT INDORE

Prabandh Shikhar, Rau-Pithampur Road, Indore-453556 (M.P.), India  
Ph. 0731-2439 620

### E-Tender Notice

**NIT / IIMI/Project/05/2018/55**

## TENDER DOCUMENT

### TECHNO COMMERCIAL PROPOSAL

Name of work:

**“Construction, Supply & Installation of Tables & Chairs for Food Court located at stilt of SR-10 at IIM Indore”**

BID ISSUE DATE	May 21, 2018
FORM OF TENDER	Item Rate Tender
LAST DATE OF BID SUBMISSION	June 9, 2018 upto 03.00 PM
DATE OF TECHNICAL BID OPENING	June 11, 2018 upto 10.00 AM

## INDEX

Sl. No.	Contents	Page No.	
		From	To
1	Detailed Notice Inviting Tender (NIT)	3	9
2	Special conditions of contract	10	14
3	Proforma of Integrity Pact	15	16
4	Proforma of Integrity Agreement	17	22
5	Safety Codes	23	23
6	Proforma of Agreement	23	25
7	Technical Specification & Indicative Drawings	26	27
8	Financial Bid	28	28

## Indian Institute of Management Indore Detailed Notice Inviting Tender

Ref: E-Tender Notice No. NIT/Project/05/2018/55

IIM Indore invites online item rate tender through e-procurement portal for the under mentioned work at IIM Indore from the bidders eligible as per the eligibility criteria mentioned in the tender document. The details are given below:

### Part “A” : NIT Details

1	NIT No.	<b>NIT/Project/05/2018/55</b>
2	Name of Work	Construction, Supply & Installation of Tables & Chairs for Food Court located at stilt of SR-10 at IIM Indore
3	Earnest Money Deposit -cum- Performance guarantee (in Rs.)	<b>Rs.37, 000/-</b> by e-payment through electronic mode which will be returned after the completion of Job.
4	Tender Processing Fee (Rs.)	<b>Nil</b>
5	Time allowed for Completion	<b>5 Weeks</b>
6	Mode of submission of tender	<b>On-Line mode only</b>
7	Pre-Bid Meeting	<b>03:00 PM on May 31, 2018</b> at Conference Hall, Administration Block, IIM Indore. Those who are interested can attend.
8	Last date and time of availability of tender in the portal	<b>Upto 03:00 PM on June 9, 2018</b> on website <a href="https://eprocure.gov.in/eprocure/app">https://eprocure.gov.in/eprocure/app</a> NIT is also available on website <a href="http://www.iimidr.ac.in">www.iimidr.ac.in</a> for view only.
9	Last date and time of closing of uploading/online submission of tender including scanned copy of EMD and tender Processing Fee details/receipts and other documents as specified	<b>Upto 03:00 PM on June 9, 2018</b>
10	Date & Time of online opening of technical bid	<b>June 11, 2018 upto 10.00 AM</b> in the Project Department, Administrative Block, IIM Indore M.P. - 453556
11	Date and Time of opening of financial bid of qualified bidders	Will be notified at a later date
12	Technical Qualifying Criteria	Conditions enlisted under Part “C” of this tender

## **Part “B” : Guidelines for e-Tendering**

1. It is mandatory for all the applicants to have class ii or iii digital signature certification from licensed certifying agency like **NIC, MTNL, e-mudra, TCS, safescrypt, GNFC** etc.
2. The tender shall be submitted online in the prescribed format before the date and time as mentioned in NIT. No other mode of submission is acceptable.
3. The applicant have to upload the details of e-payment of EMD before the last date & time and download the tender documents form the e-tendering portal <https://eprocure.gov.in/eprocure/app>.
4. Tenderer are advised to upload their documents well in time to avoid last minute rush on the server or complication in uploading. IIM indore will not be responsible for any type of problem in uploading the documents. No hard copies for tender submission shall be entertained.
5. Detailed NIT can be viewed free of cost on IIM indore website. Schedule of quantities (financial bid form) can be download only from <https://eprocure.gov.in/eprocure/app>. Uploading of tender will be possible only after making payment of Tender Processing Fee & EMD.
6. **Mode of payment of EMD:**

Bidders may deposit the EMD through NEFT or RTGS . Details for the same are as below:

Name of beneficiary	: Indian Institute of Management Indore
Address	: Rau-Pithampur Road, Indore -453556, M.P.
Account No.	: 53018623445
Name of the Bank	: State Bank of India
Address of the bank	: IIM Indore Campus
IFSC Code	: SBIN0030525

Bidders will have to upload scanned copy of Payment details towards cost of EMD during the submission of tender and the same will be accepted only on verification & confirmation by our Finance & Accounts Department. Any delay in credit will not be entertained by the Institute.

## **Part “C”: Eligibility Criteria And Other terms & Conditions**

1. Bidders who fulfill the following requirements shall only be eligible to apply (joint ventures are not accepted):

1.1 Criteria of eligibility for submission of bid documents:

- i) The bidders having experience of successfully completed works during the last 7 years ending last day of the month previous to the one in which applications are invited. The works completed upto previous day of last date of submission of tenders shall also be considered.

**One similar completed work of aggregate cost not less than Rs. 4.27 lakh value.**

1.2 **Annual Financial Turnover:** Should have had average annual financial turnover at least Rs. 5.34 Lakh during last three years ending March 31, 2018. (Scanned copy of certificate from chartered accountant to be uploaded)

1.3 **Performance / Work Experience:** Certificates of work experience and other documents as specified in the tender document shall be scanned and uploaded to the e-Tendering website.

1.4 **Certificates:** (scanned copy of original certificates to be uploaded)

1.4.1 Latest IT returns

1.4.2 PAN (Permanent Account Number)

1.4.3 GST Registration Certificate

1.4.4 Relevant work experience certificate of value not less than 4.27 Lakh

2. The bid submitted shall become invalid if:

- (i) If the bidder is found ineligible.
- (ii) If the documents submitted by the successful bidder does not match with the originals before the award of work.

3. However, certified copy of all the scanned and uploaded documents as specified in NIT shall have to be submitted by the lowest bidder only within a week physically in the office of the “ Chief Engineer, Indian Institute of Management Indore, Prabandh Shikhar, Rau - Pithampur Road, Indore 453556 (M.P.).

4. Online bid documents submitted by intending bidders shall be opened only of those bidders, **who has deposited Earnest Money Deposit and other documents scanned and uploaded are found in order.**

5. Information and Instructions for bidders posted on website shall form part of bid document.
6. The bid document consisting of plans, specifications, the schedule of quantities of various types of items to be executed and the set of terms and conditions of the contract to be complied with and other necessary documents can be seen and downloaded from website <https://eprocure.gov.in/eprocure/app> free of cost.
7. Those contractors not registered on the website mentioned above, are required to get registered beforehand. If needed the intending bidders may get acquainted with the process online from the [www.eprocure.gov.in](http://www.eprocure.gov.in) site itself.
8. The intending bidder must have valid class-II or III digital signature to submit the bid.
9. On opening date, the contractor can login and see the bid opening process. After opening of bids he will receive the competitor bid sheets.
10. Contractor can upload documents in the form of JPG format and PDF format.
11. Contractor must ensure to quote rate of each item. Therefore, if any cell is left blank and no rate is quoted by the bidder, rate of such item shall be treated as "0" (ZERO).
12. The technical bid will be opened online first on due date and time as mentioned above. The time and date of opening of financial bid of contractors qualifying the technical bid shall be communicated to them at a later date.
13. Completed Tenders containing technical bid and price bid will be received ONLINE only on CPP Portal website <https://eprocure.gov.in/eprocure/app> at the fixed time and date indicted in the NIT. The Tenderer will be at liberty to be present either in person or through an authorized representative at the time of opening of the Technical Bid with the Bid Acknowledgement Receipt or they can view the bid opening event online at their remote end.
14. The competent authority on behalf of the Director IIM Indore does not bind itself to accept the lowest or any other bid and reserves to itself the authority to reject any or all the bids received without the assignment of any reason. All bids in which any of the prescribed condition is not fulfilled or any condition including that of conditional rebate is put forth by the bidders shall be summarily rejected.
15. Canvassing whether directly or indirectly, in connection with bidders is strictly prohibited and the bids submitted by the contractors who resort to canvassing will be liable for rejection.
16. The competent authority on behalf of the Director, IIM Indore reserves to himself the right of accepting the whole or any part of the bid and the bidders shall be bound to perform the same at the rate quoted.
17. *The bid for the works shall remain open for acceptance for a period of ninety (90) days.* If any bidders withdraws his bid before the said period or issue of

letter of acceptance, whichever is earlier, or makes any modifications in the terms and conditions of the bid which are not acceptable to the department, then the IIM Indore shall, without prejudice to any other right or remedy, be at liberty to forfeit 50% of the said earnest money as aforesaid. Further the bidders shall not be allowed to participate in the rebidding process of the work.

18. This notice inviting Bid shall form a part of the contract document. The successful bidders/contractor, on acceptance of his bid by the Accepting Authority shall within 7 days from the stipulated date of start of the work, sign the contract consisting of:-
  - i) The Notice Inviting Bid, all the documents including additional conditions, specifications and drawings, if any, forming part of the bid as uploaded at the time of invitation of bid and the rates quoted online at the time of submission of bid and acceptance thereof together with any correspondence leading thereto.
  - ii) Any other Standard C.P.W.D. Form / other forms as applicable/mentioned.
19. If there are any clarifications, this may be obtained online through the tender site, or thro' the contact details. Bidder should take into account the corrigendum published before submitting the bids online.
20. It is construed that the bidder has read all the terms and conditions before submitting their offer. Bidder should go through the tender schedules carefully and upload the documents as asked; otherwise, the bid will be rejected.
21. The bidder has to digitally sign and upload the required bid documents one by one as indicated. Bidders to note that the very act of using DSC for downloading the bids and uploading their offers shall be deemed to be a confirmation that they have read all sections and pages of the bid document including General conditions of contract without any exception and have understood the entire document and are clear about the requirements of the tender requirements.
22. **The price bid format is provided in a spread sheet file like BoQ\_price bid.xls, the rates offered should be entered in the allotted space only and uploaded after filling the relevant columns. The Price Bid/BOQ template must not be modified/replaced by the bidder; else the bid submitted is liable to be rejected for this tender.**
23. The bidders are requested to submit the bids through online e-tendering system to the Tender Inviting Authority (TIA) well before the bid submission end date & time (as per Server System Clock). The TIA will not be held responsible for any sort of delay or the difficulties faced during the submission of bids online by the bidders at the eleventh hour. Tenderers are advised to upload their documents well in time to avoid last minute rush on the server.
24. The time settings fixed in the server side & displayed at the top of the tender site, will be valid for all actions of requesting, bid submission, bid opening

- etc., in the e-tender system. The bidders should follow this time during bid submission.
25. Certificate of financial turn over: At the time of submission of bid, contractor may upload Undertaking / certificate from CA mentioning Financial Turnover of last 3 Year or for the period as specified in the bid document.
  26. IF ANY INFORMATION FURNISHED by the applicant is found to be incorrect at a later stage, they shall be liable to be debarred from tendering/ taking up works in IIM INDORE.
  27. Canvassing in connection with tenders is strictly prohibited and the tenders submitted by the contractors who resort to canvassing will be liable to rejection.
  28. Short listing of the agencies shall be subject to through verification of their credentials and inspection of works carried out by them, through a Technical Evaluation committee of experts, constituted by IIM Indore.
  29. TAXES :
    - i) Contractor should get registered under GST and tax as applicable as per the extant order on the subject work shall be paid by the contractor to concerned department.
    - ii) Income Tax and cess as applicable shall be deducted from bill paid to the contractor.
    - iii) Any other taxes/cess as per government directives shall be deducted from bill paid to the contractor from time to time.
  30. For any queries regarding e-tendering process, the bidders are requested to contact as provided in the tender document. Parallely for any further queries, the bidders are asked to contact over phone: 0120-4200462, 0120-4001002, 91 8826246593 or send a mail over to [cppp-nic@nic.in](mailto:cppp-nic@nic.in)
  31. Overhead Charges: The quoted price (final offer) must be F.O.R. - IIM Indore, Indore including all overheads such as Packing, Forwarding, Loading/Unloading, Transporting, Postage/Courier, Octroi, Freight, Insurance etc.
  32. Additional Charges if any, for Installation, Packing-Unpacking, Loading/Unloading, erection, Commissioning, Inspection, Certification, Extended Warranty any other charge(s) must be included in the quoted amount.
  33. Liquidated Damages: As Time is the essence of this contract, the date of delivery should be strictly adhered to, otherwise the delivery in full or in part will not be accepted and penalty for late delivery will be imposed @ 1% on per day basis of the total value of supply order.



34. Cancellation: IIM- Indore reserves the right to accept or reject or cancel any or all enquiries or quotations at any stage without assigning any reason thereof.
35. In case of cancellation of order due to Non-compliance of the Terms and Conditions and Breach of the Contract, No compensation will be paid towards progress of order/procurement.
36. For any dispute, the place of jurisdiction shall be Indore, India only & decision of Director, IIM Indore will be final

**Part “D” : List of Documents to be scanned and uploaded**

Scanned copies of the following original certificates are to be uploaded:

- i) Certificate of experience for the value already mentioned.
- ii) Certificate of Annual turn over
- iii) Certificate of Registration for GST
- iv) Permanent Account Number (PAN)
- v) Registration certificate of firm (If any)
- vi) E-payment details towards cost of EMD
- vii) Undertaking having gone through the documents as per the Technical bid.
- viii) Any other document that bidder felt necessary in support of his candidature.
- ix) Schedule of Price Bid in the form of BoQ.xls

**IMPORTANT NOTE:**

1. Tender documents may be downloaded from Central Public Procurement Portal <https://eprocure.gov.in/eprocure/app> . Aspiring Bidders/ Suppliers who have not enrolled / registered in e-procurement should enroll /register before participating through the website <https://eprocure.gov.in/eprocure/app> . The portal enrolment is free of cost.
2. Tenderers can access tender documents on the website, fill them with all relevant information and submit the completed tender document into electronic tender on the website <https://eprocure.gov.in/eprocure/app>.
3. Tenders and supporting documents should be uploaded through e-procurement. Hard copy of the tender documents will not be accepted.
4. In the event of work award, the documents submitted by the successful bidder shall be verified with the originals before the award of work.

**Dated: May 21, 2018**  
**Place: Indore (M.P.)**

**Sd/-**  
**Chief Engineer**

## SPECIAL CONDITION OF CONTRACT

1. The tenderer shall acquaint himself with the proposed site of work.
2. The contractor shall take care of all safety precautions pertaining to work, such as scaffolding, ladder, working platforms, gangways, electric arc/ gas welding, use of hoist and construction machinery.
3. On account of security consideration, some restrictions may be imposed by the security staff on the working and/ movement of men and materials etc. The contractor shall be bound to follow all such restrictions/ instructions and he shall organise his work accordingly. No claim on this account, whatsoever, shall be payable.
4. The contractor shall take all precautions to avoid accidents by providing suitable mechanism. He shall be responsible for all damages and accidents caused to existing/ new work due to negligence on his part. No hindrance shall be caused to traffic during the execution of the work.
5. The contractor shall be responsible for the watch and ward of all materials brought by the contractor to site against pilferage and breakage during the period of installation, in campus installed, during usage and thereafter till he/she take back the same out of the campus.
6. The contractor shall take all preventive measures against any damage caused by rain, snowfall, floods or any other natural calamity, whatsoever during the execution of the work. The contractor shall be fully responsible for any damage to the Owners property and to the work for which the payment is due to him under the contract. However, the contractor shall maintain an equal to the payment received against the work done, at his own cost. This will also cover the defect liability period. This shall be favouring the Director, Indian Institute of Management Indore. Nothing extra on this account shall be payable to the contractor for maintaining such insurance Policy.
7. The work will be carried out in the manner complying, in all respects, with the requirements of relevant bye-laws of the local body under the jurisdiction of which the work is to be executed or as directed by the Engineer-in-Charge and nothing extra shall be paid on this account.
8. The contractor shall comply with proper and legal orders and directions of the local or public authority or municipality and abide by their rules and regulations and pay all fees and charges which may be liable.
9. The contractor shall give due notices to Municipal, Police and/or other authorities that may be required under the law/rules under force in the

area and obtain all requisite licenses for temporary obstructions / enclosures and pay all charges which may be leviable on account of his execution of work under the agreement. Nothing extra shall be payable on this account.

10. All materials to be incorporated in the work shall be arranged by the contractor and shall be in accordance with the specifications laid down.
11. The tenderer shall use materials bearing ISI Certification Mark unless otherwise specified or allowed in writing by the Engineer-in-Charge. Any material banned by the department shall not be used in the work.
12. The contractor shall submit to the Engineer-in-charge samples of all materials for approval. Such samples of materials which affect aesthetics of the work shall also be got approved from the Engineer-in-charge of the project before bulk supplies. These approved samples shall be preserved and retained in the custody of the Engineer-in-charge as standards of materials till the completion of the work. The cost of such samples shall be borne by the Contractor and nothing shall be payable on this account over the Agreement rates.
13. In case any material / work is found sub-standard the same shall be rejected by the Engineer-in-charge and the same shall be removed from the site of work within 48 hours, failing which the same shall be got removed by the Engineer-in-charge at the risk and cost of the contractor without giving any further notice and time.
14. Any materials brought to the site of work by the contractor shall, if required by the Engineer-in-charge, furnish manufacturer's test certificate or test certificate from approved testing laboratory to establish that the materials procured by the contractor, satisfy the provisions of relevant ISI codes. The testing charges shall be borne by the contractor.
15. The contractor shall supply free of charge the material required for testing. The cost of tests shall be borne by the contractor.
16. The work shall be executed and measured in metric system. The metric dimensions given in the schedule of quantities and drawing etc. shall be followed. (The dimension in FPS units wherever indicated are for guidance only) The figures in the drawings shall be followed.
17. The contractor shall be responsible for completing the work and for satisfying all terms and conditions of the Contract without any extra payment over his quoted rates unless otherwise specified. The contractor shall quote his rate for various items of work accordingly and no claim

whatsoever shall be entertained for any incidental or extra work involved in the execution of the work as per nomenclature of the item and the specifications indicated in the tender documents.

18. Subject to the nomenclature of the item as per schedule of quantities, the specification indicated in the tender documents, the rates quoted shall include cost of all materials including royalty and taxes if any, labour, sundry inputs, execution of work at all heights, levels, pattern and design for all leads, lifts and depths including overhead charges and contractor's profit. Nothing extra shall be paid on this account.
19. The rate shall be inclusive of making design, pattern and execution of work as per drawings, at all levels and heights.
20. The rates shall be inclusive of making any holes or otherwise for fixing any fixture/ frame work and making good the structure to its original shape and finish.
21. Other agencies doing works related with this project will also simultaneously execute the works and the contractor shall afford necessary co-ordination for un-hindered completion of these sub-works.
22. The contractor shall give a satisfactory performance test of installations individually and as a whole to ensure their proper functioning before the work is finally declared and completed and accepted.
23. The contractor shall continue to maintain watch and ward to safeguard the Owner's property in his possession until the same is formally handed over as per directions of the Engineer-in-charge. Nothing extra over agreement rates shall be paid on this account.
24. All tools, plants and measuring or weighing equipment shall be arranged by the contractor himself and nothing extra shall be paid to the contractor on this account.
25. The quantities of various items incorporated in the tender are approximate. However, the payments shall be made to the contractors on the basis of actual measurements taken at site.
26. The contractor shall protect the adjoining buildings or works and the work under execution from fire and shall make adequate arrangements for fire protection and fire fighting and if any property is damaged, by fire due to the negligence of the contractor, the same shall be made good by the contractor at his own cost, to the entire satisfaction of Engineer-in-charge.

27. The contractor shall provide adequate lighting arrangements as approved by the Engineer-in-charge for carrying out the work during night time, if so required and also provide all other facilities for the labour employed to carry out the work as per direction of Engineer-in-Charge.
28. In order to achieve the targeted date of completion the contractor may have to work in multiple shifts, round the clock including public and gazetted holidays and nothing extra shall be paid on this account.
29. All materials, articles and workmanship shall be of respective best quality and kind for the class described in the schedule of quantities and specifications. All materials, so used in different items of work shall be subject to the approval of the Engineer-in-charge .
30. The contractor shall be responsible for all statutory provisions and deductions towards ESI, PF or any other, as the case may be or any other levies and taxes shall be borne by the contractors. The TDS and Contract Tax or any other statutory levels/taxes incorporated from time to time shall be deducted progressively from the running account bills, as applicable at the time of payment. No claim in this regard shall be entertained.
31. The contractor is supposed to abide the minimum wages act, and shall produce all records to the Engineer-in-charge or any other statutory authority as and when called for. The Engineer-in-charge does not hold any responsibility on account of any lapses in this regard.
32. All spaces allotted to the contractor as described above shall be vacated and all structures removed from site at any time as and when required and directed by the Engineer-in-charge, unconditionally and without any reservation. The Engineer-in-charge will not be obliged to give any reason for such removal. Upon receiving instructions to vacate the space, the contractor shall immediately remove all his structures, materials, etc. from the sources and clear and clean-up the site to the satisfaction of the Engineer-in-charge.
33. It shall be the responsibility of the Contractor to safeguard the site and ensure that no illegal encroachments are made by outside elements within the area allotted to the contractor. Upon completion of the work or earlier as required by Engineer-in-Charge, the contractor shall vacate the land totally without any reservation.
34. The quantities indicated are for guidance only however it may vary to any extent and the contractor should not have any financial or other implications for such variations. The owner reserves to reduce the scope

of work of any item if the contractor fails to deliver the works in time and the contractor shall not ask for any financial consideration for such deletion of scope of the work.

35. Any item which is not available in the BOQ shall be paid as per actual cost of the materials in the market and actual cost of the labour plus 15% as overhead and profit. The decision of Engineer-in-charge will be conclusive and final binding on the contractor.
36. The contractor shall take photographs of site prior to commencement of work, during construction and after completion of work as suggested and shall submit the photographs in soft and hard copies to IIM for which no extra payment will be made.
37. Measurements/Layout of works shall be got checked by Engineer-in - charge & only then further work shall be taken by after approval. If at any stage deviation is found then the decision on acceptance as well as payment of the material will solely be under the jurisdiction of Engineer-in-Charge and the same will be binding on the contractor.
38. The Contractor will execute the aforesaid works subject to the provisions contained & to the extent applicable for IIM Indore CPWD's General Conditions of Contract, Special conditions of contract, Safety Code, Model Rules for the protection of health and other arrangements for workers, Specifications, Preambles and Schedule of Quantities and erection & furnishing schedule (all of which will collectively referred to as the 'tender conditions') and strictly in accordance with the Scope of work at or for the respective rates set out in the Schedule of Quantities amounting to the sum as there under arrived at or such other sums as shall become payable.
39. Agencies Black listed and Suspended from carrying out business by any Government offices, Autonomous bodies, Educational and/or research institutes, PSUs etc need not submit their quote. Suppression of information in this regard will be taken seriously.
40. The contractor is solely responsible for compliance of all labour laws and other associated statutory obligations applicable for the work. IIM Indore will not be responsible for any of the compliances or lapses in respect of the aforesaid.

**INTEGRITY PACT**

To,

.....,  
.....,  
.....

Sub: NIT No. .... for the work .....

Dear Sir,

It is here by declared that IIM Indore is committed to follow the principle of transparency, equity and competitiveness in public procurement.

The subject Notice Inviting Tender (NIT) is an invitation to offer made on the condition that the Bidder will sign the integrity Agreement, which is an integral part of tender/bid documents, failing which the tenderer/bidder will stand disqualified from the tendering process and the bid of the bidder would be summarily rejected.

This declaration shall form part and parcel of the Integrity Agreement and signing of the same shall be deemed as acceptance and signing of the Integrity Agreement on behalf of the IIM Indore.

Yours faithfully

Chief Engineer

**INTEGRITY PACT**

To,  
Chief Engineer,  
.....,  
.....

Sub: Submission of Tender for the work of .....

Dear Sir,

I/We acknowledge that IIM Indore is committed to follow the principles thereof as enumerated in the Integrity Agreement enclosed with the tender/bid document.

I/We agree that the Notice Inviting Tender (NIT) is an invitation to offer made on the condition that I/We will sign the enclosed integrity Agreement, which is an integral part of tender documents, failing which I/We will stand disqualified from the tendering process. I/We acknowledge that THE MAKING OF THE BID SHALL BE REGARDED AS AN UNCONDITIONAL AND ABSOLUTE ACCEPTANCE of this condition of the NIT.

I/We confirm acceptance and compliance with the Integrity Agreement in letter and spirit and further agree that execution of the said Integrity Agreement shall be separate and distinct from the main contract, which will come into existence when tender/bid is finally accepted by IIM Indore. I/We acknowledge and accept the duration of the Integrity Agreement, which shall be in the line with Article 1 of the enclosed Integrity Agreement.

I/We acknowledge that in the event of my/our failure to sign and accept the Integrity Agreement, while submitting the tender/bid, IIM Indore shall have unqualified, absolute and unfettered right to disqualify the tenderer/bidder and reject the tender/bid in accordance with terms and conditions of the tender/bid.

Yours faithfully

(Duly authorized signatory of the Bidder)



To be signed by the bidder and same signatory competent / authorized to sign the relevant contract on behalf of IIM Indore.

**INTEGRITY AGREEMENT**

This Integrity Agreement is made at ..... on this ..... day of ..... 20.....

**BETWEEN**

Director, IIM Indore represented through Chief Engineer,  
.....,

.....  
..., (Hereinafter referred as the ‘Principal/Owner’, which expression shall unless repugnant to the meaning or context hereof include its successors and permitted assigns)

**AND**

.....  
.....  
(Name and Address of the Individual/firm/Company)

through

.....  
(Hereinafter referred to as the  
(Details of duly authorized signatory)  
“Bidder/Contractor” and which expression shall unless repugnant to the meaning or context hereof include its successors and permitted assigns)

**Preamble**

WHEREAS the Principal / Owner has floated the Tender (NIT No. ....) (hereinafter referred to as “Tender/Bid”) and intends to award, under laid down organizational procedure, contract for.....(Name of work) hereinafter referred to as the “Contract”.

AND WHEREAS the Principal/Owner values full compliance with all relevant laws of the land, rules, regulations, economic use of resources and of fairness/transparency in its relation with its Bidder(s) and Contractor(s).

AND WHEREAS to meet the purpose aforesaid both the parties have agreed to enter into this Integrity Agreement (hereinafter referred to as “Integrity Pact” or “Pact”), the terms and conditions of which shall also be read as integral part and parcel of the Tender/Bid documents and Contract between the parties.

NOW, THEREFORE, in consideration of mutual covenants contained in this Pact, the parties hereby agree as follows and this Pact witnesses as under:

**Article 1: Commitment of the Principal/Owner**

(1) The Principal/Owner commits itself to take all measures necessary to prevent corruption and to observe the following principles:

(a) No employee of the Principal/Owner, personally or through any of his/her family members, will in connection with the Tender, or the execution of the Contract, demand, take a promise for or accept, for self or third person, any material or immaterial benefit which the person is not legally entitled to.

(b) The Principal/Owner will, during the Tender process, treat all Bidder(s) with equity and reason. The Principal/Owner will, in particular, before and during the Tender process, provide to all Bidder(s) the same information and will not provide to any Bidder(s) confidential / additional information through which the Bidder(s) could obtain an advantage in relation to the Tender process or the Contract execution.

(c) The Principal/Owner shall endeavour to exclude from the Tender process any person, whose conduct in the past has been of biased nature.

(2) If the Principal/Owner obtains information on the conduct of any of its employees which is a criminal offence under the Indian Penal code (IPC)/Prevention of Corruption Act, 1988 (PC Act) or is in violation of the principles herein mentioned or if there be a substantive suspicion in this regard, the Principal/Owner will inform the Chief Vigilance Officer and in addition can also initiate disciplinary actions as per its internal laid down policies and procedures.

**Article 2: Commitment of the Bidder(s)/Contractor(s)**

(1) It is required that each Bidder/Contractor (including their respective officers, employees and agents) adhere to the highest ethical standards, and report to the Government / Department all suspected acts of fraud or corruption or Coercion or Collusion of which it has knowledge or becomes aware, during the tendering process and throughout the negotiation or award of a contract.

(2) The Bidder(s)/Contractor(s) commits himself to take all measures necessary to prevent corruption. He commits himself to observe the following principles during his participation in the Tender process and during the Contract execution:

(a) The Bidder(s)/Contractor(s) will not, directly or through any other person or firm, offer, promise or give to any of the Principal/Owner's employees involved in the Tender process or execution of the Contract or to any third person any material or other benefit which he/she is not legally entitled to, in order to obtain in exchange any advantage of any kind whatsoever during the Tender process or during the execution of the Contract.

(b) The Bidder(s)/Contractor(s) will not enter with other Bidder(s) into any undisclosed agreement or understanding, whether formal or informal. This applies in particular to prices, specifications, certifications, subsidiary contracts, submission or non-submission of bids or any other actions to restrict competitiveness or to cartelize in the bidding process.

(c) The Bidder(s)/Contractor(s) will not commit any offence under the relevant IPC/PC Act. Further the Bidder(s)/Contractor(s) will not use improperly, (for the purpose of competition or personal gain), or pass on to others, any information or documents provided by the Principal/Owner as part of the business relationship, regarding plans, technical proposals and business details, including information contained or transmitted electronically.

(d) The Bidder(s)/Contractor(s) of foreign origin shall disclose the names and addresses of agents/representatives in India, if any. Similarly Bidder(s)/Contractor(s) of Indian Nationality shall disclose names and addresses of foreign agents/representatives, if any. Either the Indian agent on behalf of the foreign principal or the foreign principal directly could bid in a tender but not both. Further, in cases where an agent participate in a tender on behalf of one manufacturer, he shall not be allowed to quote on behalf of another manufacturer along with the first manufacturer in a subsequent/parallel tender for the same item.

(d) The Bidder(s)/Contractor(s) will, when presenting his bid, disclose any and all payments he has made, is committed to or intends to make to agents, brokers or any other intermediaries in connection with the award of the Contract.

(3) The Bidder(s)/Contractor(s) will not instigate third persons to commit offences outlined above or be an accessory to such offences.

(4) The Bidder(s)/Contractor(s) will not, directly or through any other person or firm indulge in fraudulent practice means a willful misrepresentation or omission of facts or submission of fake/forged documents in order to induce public official to act in reliance thereof, with the purpose of obtaining unjust advantage by or causing damage to justified interest of others and/or to influence the procurement process to the detriment of the Government interests.

(5) The Bidder(s)/Contractor(s) will not, directly or through any other person or firm use Coercive Practices (means the act of obtaining something, compelling an action or influencing a decision through intimidation, threat or the use of force directly or indirectly, where potential or actual injury may befall upon a

person, his/ her reputation or property to influence their participation in the tendering process).

### **Article 3: Consequences of Breach**

Without prejudice to any rights that may be available to the Principal/Owner under law or the Contract or its established policies and laid down procedures, the Principal/Owner shall have the following rights in case of breach of this Integrity Pact by the Bidder(s)/Contractor(s) and the Bidder/Contractor accepts and undertakes to respect and uphold the Principal/Owner's absolute right:

(1) If the Bidder(s)/Contractor(s), either before award or during execution of Contract has committed a transgression through a violation of Article 2 above or in any other form, such as to put his reliability or credibility in question, the Principal/Owner after giving 14 days notice to the contractor shall have powers to disqualify the Bidder(s)/Contractor(s) from the Tender process or terminate/determine the Contract, if already executed or exclude the Bidder/Contractor from future contract award processes. The imposition and duration of the exclusion will be determined by the severity of transgression and determined by the Principal/Owner. Such exclusion may be forever or for a limited period as decided by the Principal/Owner.

(2) Forfeiture of EMD/Performance Guarantee/Security Deposit: If the Principal/Owner has disqualified the Bidder(s) from the Tender process prior to the award of the Contract or terminated/determined the Contract or has accrued the right to terminate/determine the Contract according to Article 3(1), the Principal/Owner apart from exercising any legal rights that may have accrued to the Principal/Owner, may in its considered opinion forfeit the entire amount of Earnest Money Deposit, Performance Guarantee and Security Deposit of the Bidder/Contractor.

(3) Criminal Liability: If the Principal/Owner obtains knowledge of conduct of a Bidder or Contractor, or of an employee or a representative or an associate of a Bidder or Contractor which constitutes corruption within the meaning of IPC Act, or if the Principal/Owner has substantive suspicion in this regard, the Principal/Owner will inform the same to law enforcing agencies for further investigation.

### **Article 4: Previous Transgression**

(1) The Bidder declares that no previous transgressions occurred in the last 5 years with any other Company in any country confirming to the anticorruption approach or with Central Government or State Government or any other Central/State Public Sector Enterprises in India that could justify his exclusion from the Tender process.

(2) If the Bidder makes incorrect statement on this subject, he can be disqualified from the Tender process or action can be taken for banning of

business dealings/ holiday listing of the Bidder/Contractor as deemed fit by the Principal/ Owner.

(3) If the Bidder/Contractor can prove that he has resorted / recouped the damage caused by him and has installed a suitable corruption prevention system, the Principal/Owner may, at its own discretion, revoke the exclusion prematurely.

#### **Article 5: Equal Treatment of all Bidders/Contractors/Subcontractors**

(1) The Bidder(s)/Contractor(s) undertake(s) to demand from all subcontractors a commitment in conformity with this Integrity Pact. The Bidder/Contractor shall be responsible for any violation(s) of the principles laid down in this agreement/Pact by any of its Subcontractors/sub-vendors.

(2) The Principal/Owner will enter into Pacts on identical terms as this one with all Bidders and Contractors.

(3) The Principal/Owner will disqualify Bidders, who do not submit, the duly signed Pact between the Principal/Owner and the bidder, along with the Tender or violate its provisions at any stage of the Tender process, from the Tender process.

#### **Article 6- Duration of the Pact**

This Pact begins when both the parties have legally signed it. It expires for the Contractor/Vendor 12 months after the completion of work under the contract or till the continuation of defect liability period, whichever is more and for all other bidders, till the Contract has been awarded.

If any claim is made/lodged during the time, the same shall be binding and continue to be valid despite the lapse of this Pacts as specified above, unless it is discharged/determined by the Competent Authority, IIM Indore.

#### **Article 7- Other Provisions**

(1) This Pact is subject to Indian Law, place of performance and jurisdiction is the Head quarters of the Division of the Principal/Owner, who has floated the Tender.

(2) Changes and supplements need to be made in writing. Side agreements have not been made.

(3) If the Contractor is a partnership or a consortium, this Pact must be signed by all the partners or by one or more partner holding power of attorney signed by all partners and consortium members. In case of a Company, the Pact must be signed by a representative duly authorized by board resolution.

(4) Should one or several provisions of this Pact turn out to be invalid; the remainder of this Pact remains valid. In this case, the parties will strive to come to an agreement to their original intentions.

(5) It is agreed term and condition that any dispute or difference arising between the parties with regard to the terms of this Integrity Agreement /

Pact, any action taken by the Owner/Principal in accordance with this Integrity Agreement/ Pact or interpretation thereof shall not be subject to arbitration.

**Article 8- LEGAL AND PRIOR RIGHTS**

All rights and remedies of the parties hereto shall be in addition to all the other legal rights and remedies belonging to such parties under the Contract and/or law and the same shall be deemed to be cumulative and not alternative to such legal rights and remedies aforesaid. For the sake of brevity, both the Parties agree that this Integrity Pact will have precedence over the Tender/Contact documents with regard any of the provisions covered under this Integrity Pact.

IN WITNESS WHEREOF the parties have signed and executed this Integrity Pact at the place and date first above mentioned in the presence of following witnesses:

.....  
(For and on behalf of Principal/Owner)

.....  
(For and on behalf of Bidder/Contractor)

WITNESSES:

1. ....  
(signature, name and address)

2. ....  
(signature, name and address)

Place:

Dated :

## SAFETY CODES

Relevant Safety Codes of the CPWD will be applicable for the job.

### AGREEMENT

THIS AGREEMENT made at Indore on the \_\_\_\_\_ day of \_\_\_\_\_ 2014 between Indian Institute of Management Indore Rau- Pithampur Road, Indore (hereinafter called "The IIM INDORE" which expression shall, unless repugnant to the context or meaning thereof, include its administrators, successors and assigns) of the one part AND \_\_\_\_\_ (herein after called "The Contractor" which expression shall, unless repugnant to the context or meaning thereof, include its successors and permitted assigns) of the other part.

#### WHEREAS

The IIM INDORE is desirous of carrying out the work of

\_\_\_\_\_  
\_\_\_\_\_  
\_\_\_\_\_ at IIM Indore

The Works are to be executed as per the scope of work, technical specifications, drawings etc. as is mentioned in the tender document.

The Contractor has agreed to execute the said works subject to the provisions hereinafter contained and subject also to General Conditions of Contract, Special conditions of contract, Safety Code, Model Rules for the protection of health and other arrangements for workers, Specifications, Preambles and Schedule of Quantities and erection & furnishing schedule (all of which are hereinafter collectively referred to as the 'said tender conditions') and strictly in accordance with the Scope of work annexed hereto at or for the respective rates set out in the Schedule of Quantities amounting to the sum as there under arrived at or such other sums as shall become payable there under (hereinafter referred to as the said tendered amount).

#### NOW IT IS HEREBY AGREED AS FOLLOWS: -

1. In consideration of the said tendered amount to be paid by The IIM INDORE to the Contractor at the time and in the manner set forth in the said tender conditions and in accordance with the Schedule of Payments to execute and complete the work shown upon the said Drawings strictly in accordance with the specifications and Schedule of Quantities.
2. The said tender conditions, scope of work and the annexure hereto shall be read and considered as forming part of this contract and the parties hereto shall respectfully abide by to the said conditions and perform the agreement on their part respectively contained in the said conditions.

3. The approved drawings if any, notice inviting tenders technical specification etc. shall also form the basis of this contract.
4. This contract is neither a Lump sum Contract, nor a piece work contract, but is a contract on item rate basis to be carried out and to be paid for according to the Schedule of Payments at the rates contained in the Schedule of Quantities.
5. The contract herein contained shall comprise not only the works mentioned above but all subsidiary works connected therewith within the same site as may be ordered to be done from time to time by the said Engineer In charge for the time being, even if such work may not be shown on the said Drawings or described in the said Specifications and Schedule of Quantities.
6. The IIM INDORE reserves to themselves the right of altering the drawings and the nature of the work by adding to or omitting from the scope of work any item of work or portions of the same without prejudice to this contract.
7. Time shall be considered as the essence of this contract and the Contractor hereby agrees to commence the work immediately from the date of work order and shall complete the entire work within the specified period.
8. All payments by the IIM INDORE under this contract shall be made only at Indore.
9. All disputes arising out of or in any way connected with this contract shall be deemed to have arisen at Indore and courts in Indore only shall have jurisdiction to determine the same.
10. That the contract and several parts of this contract have been read by the contractor and fully understood by him. The contractor shall not be entitled for payment beyond tendered quantities unless ordered specifically by written instructions of authorized representative of IIM Indore.
11. This contract shall be signed in duplicate, the original whereof shall be kept in the custody of the IIM INDORE, and the duplicate with the Contractor.

IN WITNESS WHEREOF the IIM INDORE has set his hands hereunto and two duplicates hereof through his duly authorized official and the Contractor has caused these presents and two duplicates hereof under his common seal by his duly authorized representative at the place and on the date month and year first herein above written.

SIGNED, SEALED AND DELIVERED by IIM INDORE, by the hand of

Signature:  
Name:  
Designation:



IN THE PRESENCE OF

(1) Signature:  
Name:  
Address:

(2) Signature:  
Name:  
Address:

SIGNED, SEALED AND DELIVERED BY the Contractor M/s. \_\_\_\_\_  
\_\_\_\_\_.

Signature:  
Name:  
Designation:

IN THE PRESENCE OF

(1) Signature:  
Name:  
Address:

(2) Signature:  
Name:  
Address:

## Technical Specification & Indicative Drawings

### Chair:

1. **Seat and Back** are to be injection molded in high impact strength Polypropylene polymer compound with indoor grade UV resistance.
2. **Seat size** to be: W-525 mm x D-530 mm.
3. **Back Size** to be: W-510 mm x H-400 mm.
4. **Understructure:** The tubular welded frame is to be made of Dia 2.22 +/- 0.03 cm x 0.12 +/- 0.0128 cm and 3.5 +/- 0.03 x 1.5 +/- 0.03 cm x 0.12 +/- 0.0128 cm stainless steel 202 grade tube. The tubes are buff polished to give shiny surface.
5. **Shoes of the legs** are to be made of high impact strength Polypropylene polymer compound with indoor grade UV resistance and press fitted with tubular frame.
6. **Overall dimensions:** Width-52 Cms. x D - 55 Cms. x H - 84 Cms. x Seat Height - 45 Cms.

(STAINLESS STEEL UNDERSTRUCTURE)

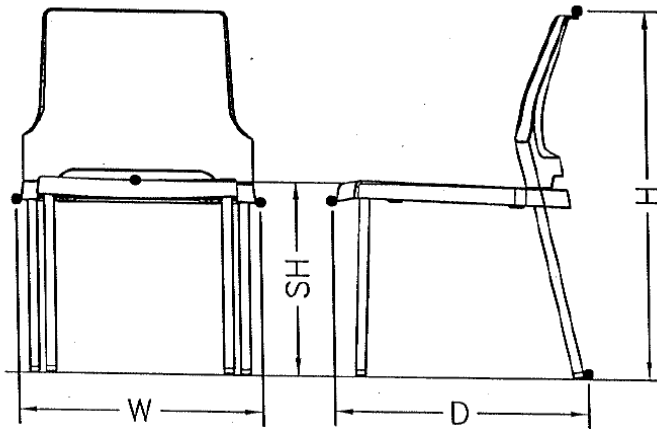

WIDTH (W):	52.5 CM
DEPTH (D):	55.8 CM
HEIGHT (H):	84.5 CM
SEAT HEIGHT (SH):	45.0 CM.

### Table:

1. **Size:** 900 mm round top which will be made up of granite pasted / supported on 25 mm thick marine grade ply.
2. **Bottom frame:** made of SS 202 grade pipe dia. 63.1mm x 2 mm thick at center connected to top pipe size 40x20x2mm in a cross shape and at bottom pipe size 40x40x2mm thick welded.
3. There will be fix adjuster at the bottom of the frame.

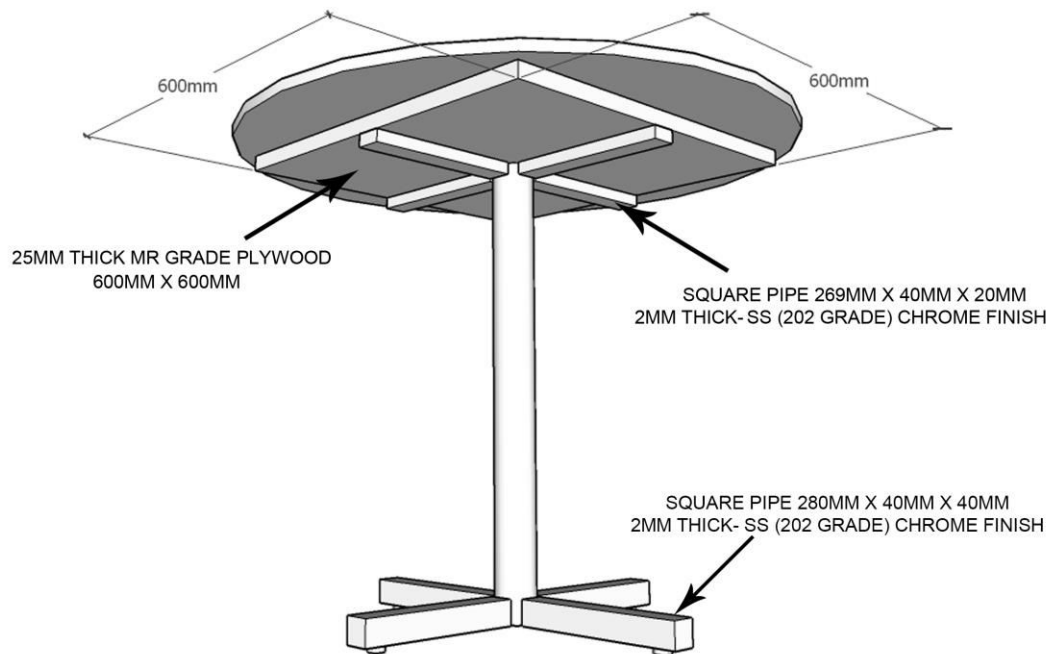
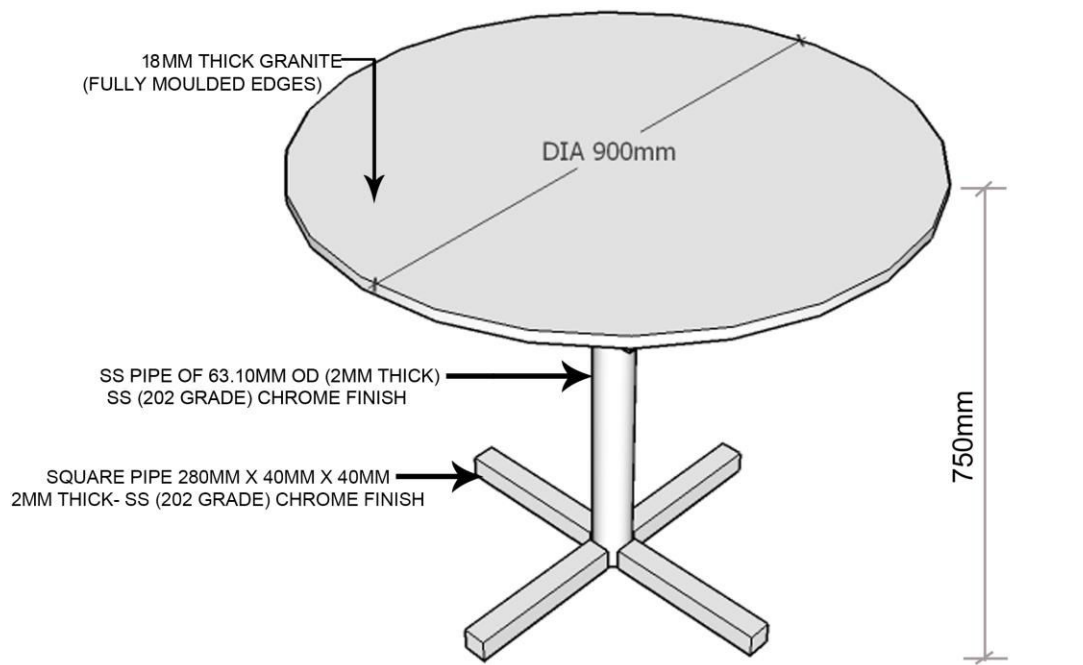

**FINANCIAL BID**

**For**

**Construction, Supply & Installation of Tables & Chairs for  
Food Court located at stilt of SR-10 at IIM Indore**

**As per the Financial Bid available on the following link of  
e- procurement website**

**<https://eprocure.gov.in/eprocure/app>**